

FMC-04

Designed for heavy-duty displays, the AG Neovo FMC-04 is an easy to move and adjust floor mobile cart for training or presentation applications.

The FMC-04 floor mobile cart, working with AG Neovo wall mount kit (LMK-04), features easy-movement and durability. The smart cable management structure and lockable wheels keep cable organized and ensure the display remains secure. Landscape and portrait display orientation is also available for versatile applications, especially for large touch screen. The FMC-04 is ideal for heavy-duty displays in public and multi-user environments for training or presentation purpose.



Dimensions (Unit: mm)

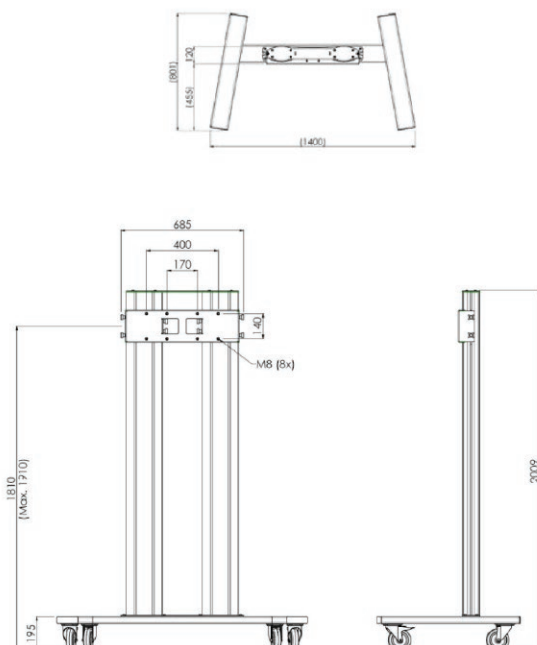

- > Durable design for multi-user environments
- > Landscape or portrait display orientation
- > Display height adjustable up to 1,810 mm (centre display)
- > Narrow footprint allows easy mobility especially through doors or elevators
- > Cable duct for smart cable management
- > Locking casters to prevent the wheel from rotating
- > Weight capacity: 160.0 kg (352.7 lb)
- > Mounting bracket / interface between display and floor mounting cart is necessary and excluded (LMK-04)
- > Ideal for heavy-duty displays and large touch screens

Specifications

Loading	Weight Capacity	160.0 kg (352.7 lb)
Adjustment	Lift (Max. centre display)	1,810 mm (71.3")
Exterior	Material	Aluminium
	Colour	Dark grey and Silver
Dimensions	Net (W x H x D)	1450.0 x 2100.0 x 850.0 mm (57.1" x 2.7" x 33.5")
	Packaging (W x H x D)	1450.0 x 2200.0 x 850.0 mm (57.1" x 86.6" x 33.5")
Weight	Product Weight	68.0 kg (149.9 lb)
	Packaged Product Weight	85.0 kg (187.4 lb)
Packing	1 Pallet	1 set